



# Speech Controlled DC Switch

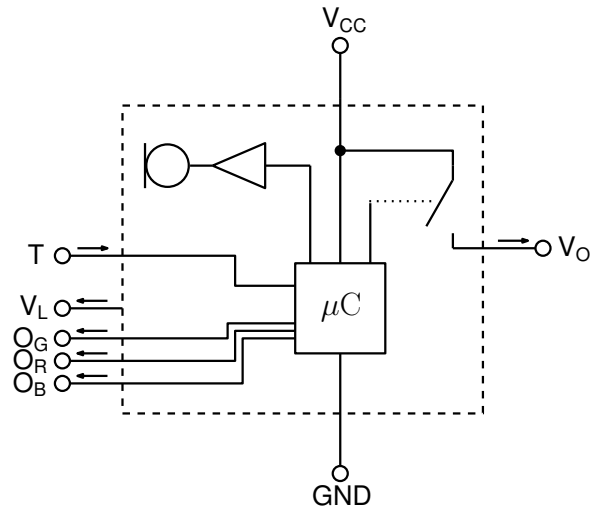

Figure 1: Representative Schematic Diagram

## 1 Features

- on/off switching by signal and by speech
- programmable speech command
- high-side switched output
- operation between 12 and 30V
- low power consumption
- output switch current up to 3A
- small outline package sealed by epoxy

## 2 Description

The SB-DC-SW-1 is an easy to use speech-controlled DC high-side switch with an load up to 3A. The output can be activated and deactivated by an external push button or with an user definable speech command.

Because of an integrated switching regulator the SB-DC-SW-1 can operate with a wide voltage input range between 12 and 30V with low power loss.

The SB-DC-SW-1 is intended to extend the functionality of various consumer electronic devices, such as table lamps, alarm clocks or furniture with integrated lighting.

## 3 Connection Diagram

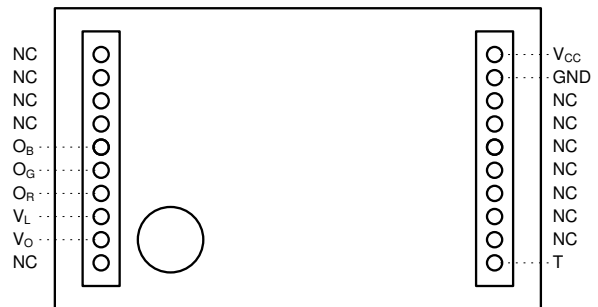

Figure 2: Bottom View



## 4 Minimum and Maximum Ratings

Rating	Symbol	Min value	Max value	Unit
Power Supply Voltage	$V_{CC}$	12	30	Vdc
Switch Current	$I_O$	-	3	A
Status LED Current (Pin $V_L$ )	$I_L$	-	20	mA
Operating Ambient Temperature Range	$T_A$	0	70	°C

## 5 Electrical Characteristics

Rating	Symbol	Typ. value	Unit
Power Dissipation	$P_D$	0.5	W
Status LED Voltage (Pin $V_L$ )	$V_L$	3.3	V

## 6 Typical Application

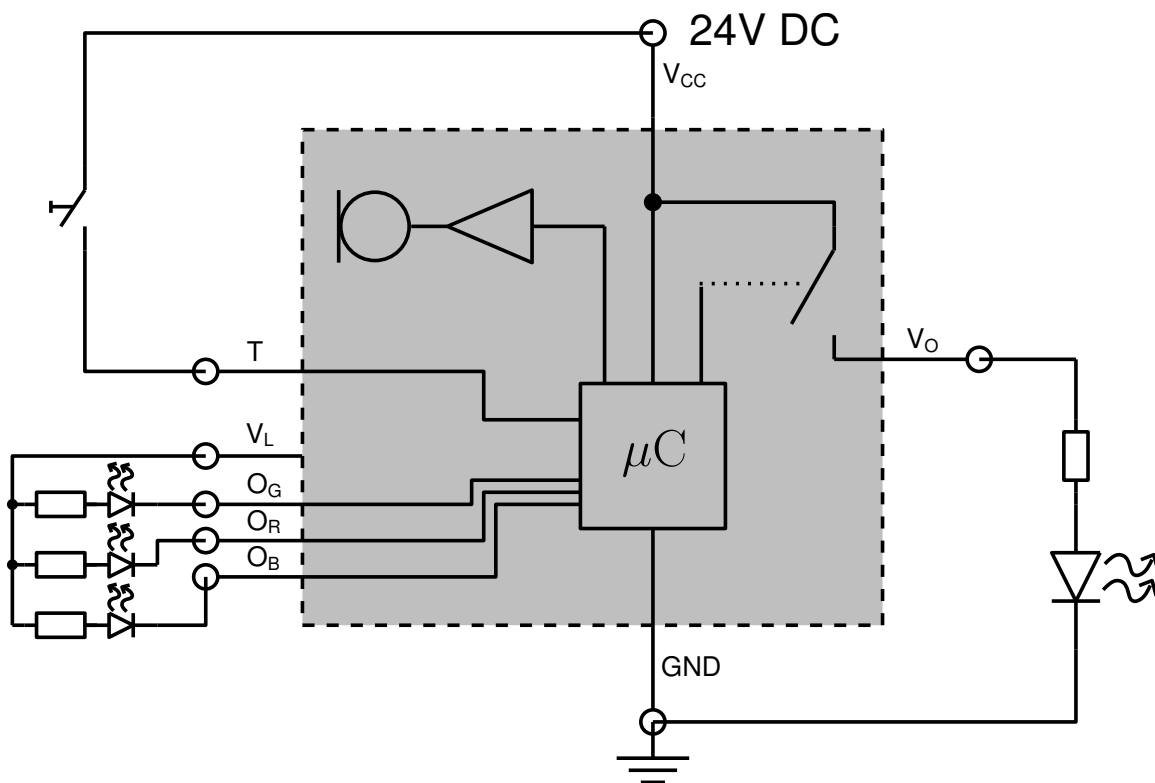

Figure 3: Typical Application: LED or Halogen lamp switch



## 7 Operating Instructions

Note: The following explanations relate to the application in Fig. 3.

### 7.1 Manually Turning the Light On/Off

A short press of the button turns the light on or off. The switch event occurs by releasing the button.

### 7.2 Turning the Light On/Off with Speech

Switching with speech commands is similar to switching manually. The switch event occurs upon recognition of a programmed command (see section 7.3).

### 7.3 Programming a New Speech Command

The programmed speech commands are used for both, switching on and off. They should contain at least 5 syllables. The more syllables they have, the lower the likelihood of unwanted false recognition. A recommendable approach is to choose the place of installation or the name of the targeted device as the command (for example “switch living room light”, “toggle workroom light”, “switch table light”). The maximal permitted command length is 2 seconds.

**Command Recording:** Push button for about 3 seconds, after which the LED  $O_G$  goes on. Now the user can say the desired speech command. Immediately afterwards the finger should be released from the button. The LED  $O_G$  starts to blinking.

**Variance Training:** The user needs to repeat the desired command several times until the LED  $O_G$  stops blinking. It is not necessary to push the button during variance training. After each recognition the state of the switch changes. Between each repetition it is necessary to wait at least two seconds, even in the case of a non-recognition. If the variance training fails, the user should delete all programmed speech commands and rerecord the command.

**Notes: Everything the device hears during recording will be incorporated into the command. Unintended noise or gaps at the start and end should therefore be avoided. It is also important to speak clearly and plainly, but not abnormally stretched, loud or quiet. A minimum distance of about 50 cm to the microphone should be taken into account.**

With the described method it is possible to program up to three different commands.

### 7.4 Deleting all Speech Commands

When the button is pressed for about three seconds and released immediately (i.e. as soon as LED  $O_G$  is lit), all speech commands are deleted.



## 8 Package Dimensions

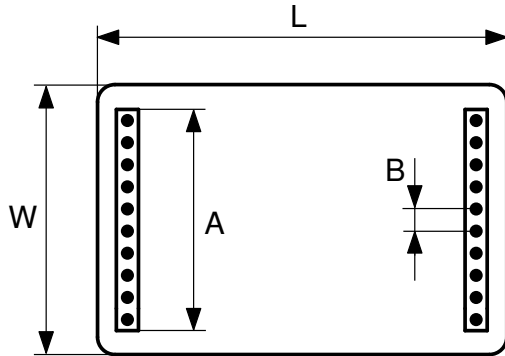

BOTTOM VIEW

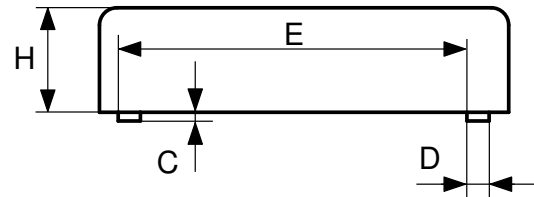

SIDE VIEW

Dim	Millimeters	Inches
L	47.0	1.85
W	31.0	1.22
H	12.0	0.47
A	26.0	1.02
B	2.5	0.10
C	1.0	0.04
D	2.5	0.10
E	40.0	1.57



AURINOVO GmbH

Luisenstraße 7  
D-14542 Werder (Havel)

+49(0)3327 567082  
<http://www.aurinovo.com>